

**FEATURES**

- ◆ Loaded vinyl noise barriers
- ◆ Reinforced, non-reinforced, transparent and foil-faced lag styles
- ◆ Mass loaded barriers from 1/2 lb. to 2 lbs. per sq. ft.
- ◆ Acoustical ratings: STC-20 thru STC-31
- ◆ Limp, flexible, formable, versatile
- ◆ High tear and tensile strength
- ◆ For industrial, construction, commercial, residential and OEM applications

ArtUSA Flexible Noise Barriers are available in a variety of styles to meet a multitude of applications.

Non-Reinforced Barriers:

#### B-10NR

- ◆ 1 lb. PSF non-reinforced loaded vinyl noise barrier
- ◆ Low-cost, often used between dry wall and stud construction to substantially improve transmission loss between rooms (see photo)
- ◆ Used as the barrier septum material in acoustical curtain and foam composites
- ◆ An economic acoustical pipe or duct wrap
- ◆ Utilized as a rooftop equipment noise barrier
- ◆ Used as a noise barrier ceiling tile (typically in conjunction with a fiberglass decoupler) above standard suspended ceiling systems
- ◆ Used underneath carpeting to improve transmission loss of floor

#### B-5NR

- ◆ 1/2 lb. PSF version of the above
- ◆ Used where weight restrictions require a lighter weight barrier

#### B-20NR

- ◆ 2 lb. PSF version of the above
- ◆ For applications requiring greater noise reduction, especially at lower frequencies

2"x4" Wood Stud-



B-10NR

B-10 NR attached to studs before drywall is installed will significantly reduce noise transmission between rooms.

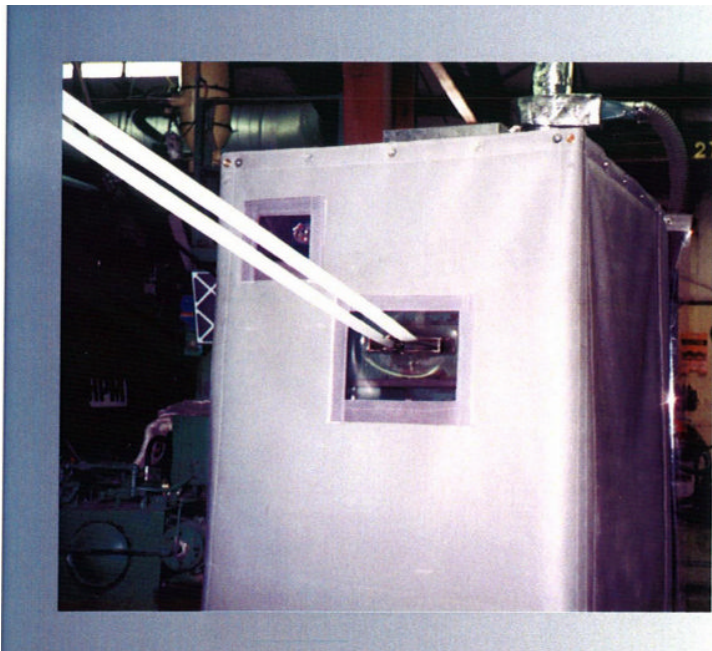

Reinforced Barriers:

#### B-10R

- ◆ 1 lb. PSF reinforced loaded vinyl noise barrier
- ◆ High-strength polyester fabric reinforcement is utilized in the center of the barrier to dramatically improve its durability, tear and hanging strength
- ◆ Excellent outdoor UV and weather resistance
- ◆ Can serve as accordion fold access door
- ◆ Used as a free hanging acoustical curtain panel, typically with grommets at the top and hook and loop fasteners along each edge (see photo)
- ◆ When used in combination with a Quilted Fiberglass Sound Absorber, (BBC-13, BBC-13-2"F) can offer STC Ratings up to 32 (See Bulletin SS101)
- ◆ Standard color is gray. Tan and blue are also available

#### B-5R

- ◆ 1/2 lb. PSF reinforced loaded vinyl
- ◆ Same properties as above, utilized where weight restriction require a lighter weight material

## Pipe and Duct Lagging:

### B-10 LAG

- 1 lb. PSF reinforced-foil faced loaded vinyl noise barrier
- Acoustical wrap for noisy pipes, duct work, valves, heat exchangers
- Easy to cut, wrap and install with matching lag tape
- May be combined with quilted fiberglass decoupler to improve acoustical performance, thermal conductivity and lower installation costs
- Class A flammability rating requirements per ASTM E-84
- Durable reinforced foil facing serves as protective jacket as well as readily accepts matching tape

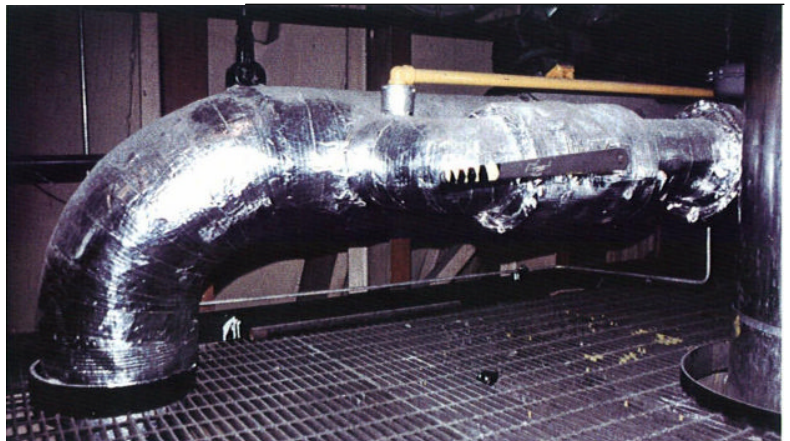

B-10 LAG/QFA-3 Acoustical Pipe Log installed on 12" diameter pipe with matching lag tape. See Sound Seal bulletin SS-105 for additional information.



Clear vinyl strip installed on loading dock door allows easy access while offering thermal protection and noise reduction.

### Transparent Barriers:

- Flexible transparent barrier materials offer significant noise reduction while allowing for visibility and easy access
- Also utilized to reduce heat and cold loss between areas
- Sheet material is often utilized as a view window in Sound Seal Acoustical Curtain Panels
- CV strip doors are often incorporated into Acoustical Curtain Enclosures for easy access
- Mounting angles and hardware are also available.
- Furnished in three standard products:

B-10 CV	B-7.5 CV	B-5 CV
◆ 1 PSF	◆ 3/4 lb. PSF	◆ 1/2 lb. PSF
◆ 16" wide strips	◆ 12" wide strips	◆ 8" wide strips
◆ 48" wide sheets	◆ 48" wide sheets	◆ 48" wide sheets
◆ Curtain panels with grommets at top and velcro edges	◆ Custom-sized fabrications	◆ Custom-sized fabrications
◆ Custom-sized window covers		

### B-10L

- ◆ 1 lb. PSF lead sheet
- ◆ Commonly used as a septum product in acoustical composites
- ◆ Utilized where radiation or RF resistance are required in addition to noise reduction

### Specialty Barriers:

#### B-10MB

- ◆ 1 lb. PSF barrier material with a woven-fiberglass cloth facing
- ◆ Typically referred to as "marine barrier"
- ◆ Superior fire ratings when installed against bulkheads, etc.

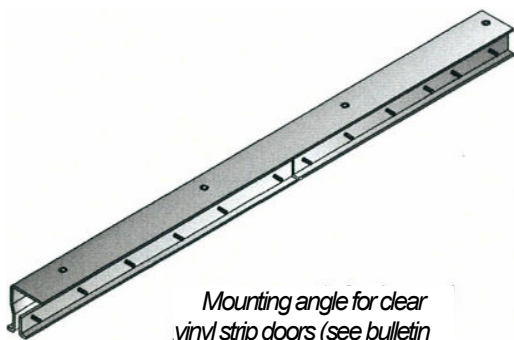

Mounting angle for clear vinyl strip doors (see bulletin)

# Flexible Barriers

## Noise Transmission Loss

Barriers	Noise Transmission Loss (dB) Per Octave Band (Hi)						STC
	125	250	500	1000	2000	4000	
2 lb. PSF	16	22	26	32	35	40	31
1lb. PSF	13	17	22	26	32	37	26
3/4 lb. PSF	11	16	20	25	30	34	23
1/2 lb. PSF	8	13	17	22	27	31	20

Per ASTM: E 90 (90A)

## Physical Properties

Product	Nom. Thickness (in.)	Nom. Weight lb/sq. ft.	Description	Roll Size	Additional Details
B-10 NR	.107	1.0	Non-Reinforced	54"Wx60'L	See Bulletin SS101
B-5 NR	.042	.5			
B-20 NR	.225	2.0			
B-10 R	.090	1.0	Reinforced	54"Wx30'L	See Bulletin SS105
B-5 R	.050	.5			
B-10 LAG	.090	1.0	Foil Faced	54"Wx30'L	See Bulletin SS105
B-10 CV	.160	1.0	Transparent	16"Wx100'L & 48"Wx60'L	Mounting Hardware Details See Bulletin SS102
B-7.5 CV	.120	.75		12"Wx200'L & 48"Wx60'L	
B-5 CV	.080	.5		8"Wx300'L & 48"Wx60'L	
B-10 L	.020	1.0	Lead Sheet	48"Wx25'L	SS104
B-10MB	.100	1.0	Marine Barrier	38"Wx45'L	

Additional information on tensile, breaking and tear strengths, elongation, chemical resistance, flammability, etc. is available upon request.

The test results reported were obtained using standard laboratory procedures recognized by the technical community. The data is valid as a measurement of the material under specific controlled test conditions. However, this data does not represent an accurate indicator of the performance of the material or of the hazards which may exist under actual field conditions.

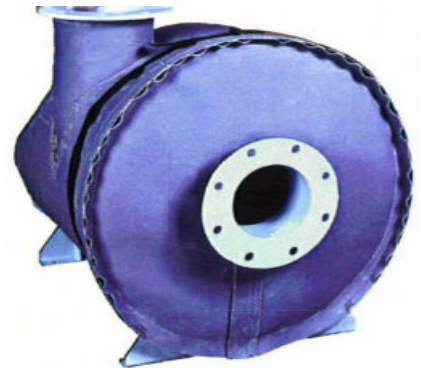

For OEM Applications  
Call 888-454-6975