



"The ART of Noise Control"

For your local ArtUSA Representative

Call: 1-888-454-6973

Internet: www.artusaindustries.us

Modular Acoustical Panels

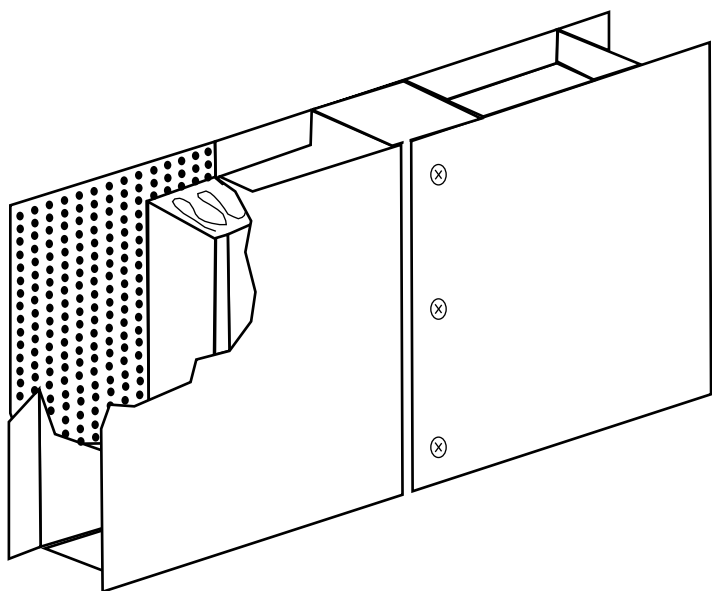

Options:

- ★ STC Rated Panels up to 55 dBA
- ★ Mylar, Polyethylene, or Fiberglass Cloth Lining
- ★ Framed Cutouts/Openings
- ★ Primer or Finish Paint
- ★ Multiple Gauge Construction Available
- ★ Multiple Materials are Available
- ★ Custom Designs per Your Acoustical/Thermal Requirements
- ★ Multiple Insulation Materials and Densities are available

Construction:

ArtUSA standard Acoustical/Thermal Panels are fabricated with an 18 gauge G90 galvanized solid steel outer skins and 16 gauge galvanized solid steel channel frames filled with mineral-glass fiber acoustic/thermal fill; and are protected by an inner skin which consists of a 22 gauge G90 galvanized perforated steel sheet with 23% open area (3/32" holes on 3/16" staggered centers).

FEATURES:

- ★ ALL TRIM IS 16 GAUGE GALVANIZED SOLID STEEL FURNISHED IN 10 FOOT LENGTHS FOR EASE OF INSTALLATION
- ★ ALL STRUCTURAL STEEL, WHERE SUPPLIED BY ArtUSA INDUSTRIES, WILL HAVE PRIMER COAT PAINT APPLIED AT THE FACTORY
- ★ ArtUSA FURNISHES ALL NECESSARY DRAWINGS FOR APPROVAL AND ERECTION, AS WELL AS ANY STRUCTURAL AND OR SEISMIC CALCULATIONS AS REQUIRED.
- ★ ALL FASTENERS ARE ZINC PLATED, SELF-DRILLING, SELF- TAPPING SHEET METAL SCREWS
- ★ ArtUSA OFFERS THE OPTION OF EITHER PANEL CONNECTOR, OR TONGUE & GROOVE PANEL CONSTRUCTION



"The ART of Noise Control"

For your local ArtUSA Representative

Call: 1-888-454-6973

Internet: www.artusaindustries.us

Modular Acoustical Panels

Acoustical Performance* - Standard Construction

Sound Transmission Loss (ASTM E90-81)

*All acoustical tests were performed and reported by an independent Accredited Acoustical Laboratory. Copies of the test reports can be furnished upon request.

Octave Band Center Frequency (Hz)	125	250	500	1000	2000	4000	STC
4" Panel (TL in dB)	22	29	40	48	54	60	41
2" Panel (TL in dB)	21	24	35	43	52	57	37

Sound Absorption Coefficients (ANSI/ASTM C243-81a and E795)

Octave Band Center Frequency (Hz)	125	250	500	1000	2000	4000	NRC
4" Panel	.86	1.09	1.22	1.06	1.05	1.04	1.10
2" Panel	.31	.82	1.19	1.12	1.07	1.06	1.11

Structural Performance:

The entire enclosure shall be self-supporting and air-tight up to a pressure differential of 10 inch Water Gauge. When needed, additional structure support can be provided to assure that the enclosure will be air-tight and not deflect more than 1/240th of the longest span.

Thermal Performance:

Individual panels will have a "U" factor 0.07 and an entire panel enclosure will have a "U" Factor of 0.14

Fire Hazard Rating:

Standard acoustical fill will have the following UL Fire Hazard Ratings as per ASTM E-84:

FLAME SPREAD -15 / FUEL CONTRIBUTED -0 / SMOKE DEVELOPED -0